



STEEL SLIDING FIREDOORS

PORTONI TAGLIAFUOCO IN ACCIAIO

THE ITALIAN STYLE DOOR

Dierre

YOUR HOME, YOUR LIFE

7	ROLLING SCORREVOLE ORIZZONTALE TAGLIAFUOCO MARCATO CE <i>CE MARKED SLIDING HORIZONTAL FIREDOOR</i>
9	CERTIFICAZIONI: DIRETTIVA MACCHINE E MARCATURA CE <i>CERTIFICATIONS: MACHINERY DIRECTIVE AND CE MARKING</i>
10	PERFORMANCE E CARATTERISTICHE TECNICHE, IN DETTAGLIO <i>PERFORMANCE AND SPECIFICATIONS, IN DETAIL</i>
14	OPTIONAL
15	SOLUZIONI DI FISSAGGIO <i>FITTING SOLUTIONS</i>
17	SCHEDE TECNICHE <i>TECHNICAL SHEETS</i>
27	CROSS SCORREVOLE VERTICALE TAGLIAFUOCO AD USO PASSAVIVANDE <i>FIRE-RATED VERTICAL SLIDING SERVING HATCH</i>
29	CERTIFICAZIONI E CONFORMITÀ DI PRODOTTO <i>CERTIFICATIONS AND PRODUCT CONFORMITY</i>
30	PERFORMANCE E CARATTERISTICHE TECNICHE, IN DETTAGLIO <i>PERFORMANCE AND SPECIFICATIONS, IN DETAIL</i>
32	OPTIONAL
33	SCHEDE TECNICHE <i>TECHNICAL SHEETS</i>
37	TAVOLA SINOTTICA <i>SYNOPTIC TABLE</i>



Rolling SB1 singolo battente
Rolling SB1 single leaf



Rolling SA1 singolo battente
Rolling SA1 single leaf



Cross laccato RAL 9010
Cross lacquered RAL 9010

ROLLING

SCORREVOLE ORIZZONTALE TAGLIAFUOCO MARCATO CE

CE MARKED SLIDING HORIZONTAL FIREDOOR

COMPONENTI FISSI: Guida orizzontale, fissata a muro tramite staffe di sospensione a tassellare, con sagoma a tenuta fiamme e calore e profilo a doppia rotaia con 2 carrelli ognuno dotato di 2 ruote, al variare di larghezze e altezze in aumento, vengono forniti carrelli di scorrimento aggiuntivi, sporgenza guida dal muro 230 mm. Lato testa, cassonetto fissato al muro tramite tasselli metallici, dotato di un incontro femmina per fiamme e calore che racchiude i pesi collegati all'anta tramite cavo in acciaio per l'autochiusura dell'anta. Lato coda, labirinto fisso per tenuta fiamme e calore fissato al muro tramite tasselli metallici, in accoppiamento con labirinto mobile avvitato sul lato coda dell'anta, assicura la tenuta fiamme e calore con anta chiusa. Guida inferiore a pavimento, rullo fissato a pavimento fuori luce di passaggio con scorrimento in guida ricavata sul lato inferiore dell'anta scorrevole. Tutti gli elementi fissi sono in lamiera zincata e verniciata con polvere epossipoliestere colore avorio chiaro simile al RAL 9010.



COMPONENTI SCORREVOLI: Anta scorrevole, sospesa alla guida tramite i carrelli di scorrimento composta da 2 o più moduli al variare della larghezza in aumento. I moduli si accoppiano con sistema maschio/femmina avvitati, il modulo lato testa è provvisto di maniglie incassate, il modulo lato coda è dotato di labirinto mobile di tenuta fiamme e calore. I moduli sono in lamiera di acciaio zincato e preverniciato avorio chiaro simile al RAL 9010 con pellicola di protezione da asportare a posa ultimata, coibentazione ad alta densità. Spessore anta 80 mm, aria tra anta e muro 75 mm. Apertura destra con scorrimento orizzontale a destra, apertura sinistra con scorrimento orizzontale a sinistra. Opzioni: contrappeso in coda, architrave coibentata, porta pedonale (non sono considerate vie di fuga ma porte di servizio), regolatore di velocità, ammortizzatori di fine corsa, motorizzazioni antincendio con possibilità funzionamento portone con blocco posizione anta tramite freno motore, verniciature RAL a scelta. Per tutti gli scorrevoli è obbligatorio l'extra ammortizzatore di fine corsa e, per misure in larghezza superiore a 3 m oppure superficie superiore a 12 mq, obbligatorio l'extra regolatore di velocità. Due opzioni importanti sotto il profilo della sicurezza per il transito di persone o mezzi.

FIXED COMPONENTS: horizontal guide, fixed to the wall by means of bolt-in suspension brackets flames and dual rail profile with 2 carriages, each with 2 wheels, as widths and heights vary, additional sliding carriages are provided, guide overhang from wall 230 mm. Head side, box fixed to the wall by means of metal blocks, equipped with a female strike for flames that encloses the weights connected to the wing by means of a steel cable for self-closure of the wing. End side, fixed labyrinth for flames fixed to the wall by means of metal blocks, coupled with mobile labyrinth screwed on the end side of the wing, ensures the sealing of the flames with the door closed. Lower floor guide, floor fixed roller outside passage with guide sliding formed on the lower side of the sliding door.

All fixed elements are galvanized and painted with epoxy polyester powder, light ivory color similar to RAL 9010.

SLIDING COMPONENTS: Sliding door, suspended from the guide through the sliding carriages composed by 2 or more modules as the width increases. The modules are coupled with a screwed male/female system, the module on the head side is provided with recessed handles, the module on the end side is equipped with that ensures the sealing of the flames mobile labyrinth. The modules are made of galvanized and prepainted sheet steel, light ivory similar to RAL 9010 with protective film to be removed once the fitting operation is complete, high density insulation. Leaf thickness 80 mm, space between the door and the wall 75 mm. Right opening with horizontal sliding to the right, left opening with horizontal sliding to the left. Options: counterweight on the end, insulated architrave, pedestrian door (not to be considered as escape routes but service doors), speed control, end-of-stroke dampers, fire-rated motors with the possibility to operate the door with position locking of the leaf through motor brake, painting

RAL at choice. For all the sliding doors it is mandatory the extra end damper and, for measures in width exceeding 3 m or surface over 12 sq.mt, it is mandatory to fit the extra speed regulator. Two important safety options for the transit of people or means.



Dierre
 YOUR HOME, YOUR LIFE

DICHIARAZIONE DI PRESTAZIONE n.20190PC030000000791-05800020610058

- Codice di identificazione unico del prodotto - tipo:
ROLLING ante singola
- Usi previsti, conformemente alla relativa specificazione armonizzata, come previsto dal fabbricante:
(USI SPECIFICI DICHIARATI E/O ALTRI USI SOGGETTI A REQUISITI SPECIFICI IN TERMINI DI RUMorosITÀ, SICUREZZA, RESISTENZA E SIDA, RESOZZA, ETC.)
- Nome, denominazione commerciale registrata o marchio registrato e indirizzo del fabbricante:
TREDI, Strada della Valsella, 21, 14019 Villanova d'Adda (AT), Italia
- Sezione di valutazione e verifica della conformità della prestazione (secondo VVDI):
Sistema 3
- Norma armonizzata:
EN 13241:2009/A2:2016 Parte e Cancelli (in vendita, Commerciali e da Garage - Norme di Prodotto, Caratteristiche Prestazioni)
- Organismo notificato:
0474 - RINA
- Produttore Dichiarante:

Caratteristiche Essenziali	Prestazione	Norma armonizzata
Apertura scivola	è richiesta	non applicabile
Durabilità della pannello infisso	valore	NPD
Durabilità della lamina sfiorante	valore	NPD
Durabilità della lamina scorrevole	valore	NPD
Poca di insonorizzazione	espressione	NPD
Prevedibilità sfiorante	valore	NPD
Resistenza al carico del vetro - presenza di impronte	valore	2
Costanze velocità	espressione	come richiesto dai regolamenti
Totale sfiorante	valore	NPD
Temperatura minima	Valore	NPD
Resistenza ambientale e stabilità	espressione	questi
Definizione giuridica componenti infisso	valore	non applicabile

Note: NPD: no performance dichiarate (nessuna prestazione dichiarata)
 La prestazione del prodotto è verificata e conforme all'insieme delle prestazioni dichiarate.
 La presente dichiarazione di responsabilità viene emessa, in conformità al regolamento (UE) n.305/2011, sotto la sola responsabilità del fabbricante sopra specificato.

Firmato a nome e per conto del Fabbricante da:
 Alessandro De Roberto Amministratore Delegato

Luogo e Data del rilascio: Villanova d'Adda (AT) 21/11/2018

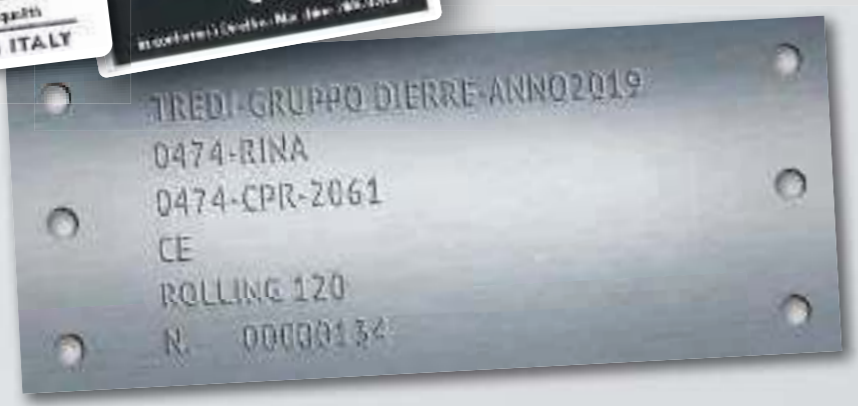

CERTIFICAZIONI: DIRETTIVA MACCHINE E MARCATURA CE

Il portone scorrevole **Rolling** è **marcato CE** secondo le norme di prodotto **EN 13241** e **EN 16034**. Per poter ottenere tali marcature è necessario sottoporre il processo produttivo ed il prodotto stesso a specifici iter e controlli che garantiscano il fatto che tutta la fase produttiva avvenga nelle modalità e con i componenti descritti nei vari documenti di prova.

Alla marcatura CE secondo la EN 16034 per prodotti tagliafuoco sono legate tutta una serie di norme definite EXAP che permettono estensioni di vario genere sul prodotto a fronte di prove al fuoco effettuate secondo la EN 1634-1. La marcatura CE su questo tipo di prodotti è obbligatoria dal 1/11/19, da tale data è quindi obbligatorio fornire l'unico documento che accompagna la marcatura: la DoP (dichiarazione di prestazioni).

Sul prodotto deve essere apposta un'etichetta che renda rintracciabile il prodotto, non è obbligatoria la targhetta metallica che però viene comunque applicata sul Rolling per garantire un'identificazione nel tempo.

Il prodotto Rolling è classificato **EI₂120** nelle versioni ad 1 e a 2 ante, con e senza portina pedonale, in piccole e grandi dimensioni.

Tale tipologia di prodotto, a prescindere che sia motorizzato o meno, deve anche soddisfare i requisiti della Direttiva Macchine, per questo viene quindi anche marcato in conformità alla **Direttiva Macchine 2006/42/CE**.

CERTIFICATIONS: MACHINERY DIRECTIVE AND CE MARKING

The sliding door **Rolling** is **CE marked** according to the product standards **EN 13241** and **EN 16034**. The production process and the product itself must undergo specific procedures and controls in order to be able to obtain these markings that ensure that all the production phase takes place with the methods and using the components described in the various test documents.

A whole series of standards called EXAP are linked to the CE marking according to the EN 16034 standard for fire products that allow various kinds of extensions on the product for fire tests performed according to EN 1634-1. The CE marking on this type of product has been mandatory since 1/11/19 and from that date it is therefore compulsory to provide the only document that accompanies the marking: the DoP (declaration of performance). The product must carry a label that makes the product traceable. A metal plate is not compulsory but it is in any case applied to Rolling to ensure an identification in time. Rolling is classified **EI₂120** in the single and double leaf versions, with and without pedestrian door, in small and large dimensions.

This type of product, whether motorized or not, must also meet the Machinery Directive requirements, this is the reason being for it to be also marked in accordance with Machinery Directive 2006/42/CE.

PERFORMANCE E CARATTERISTICHE TECNICHE, IN DETTAGLIO

PERFORMANCE AND SPECIFICATIONS, IN DETAIL

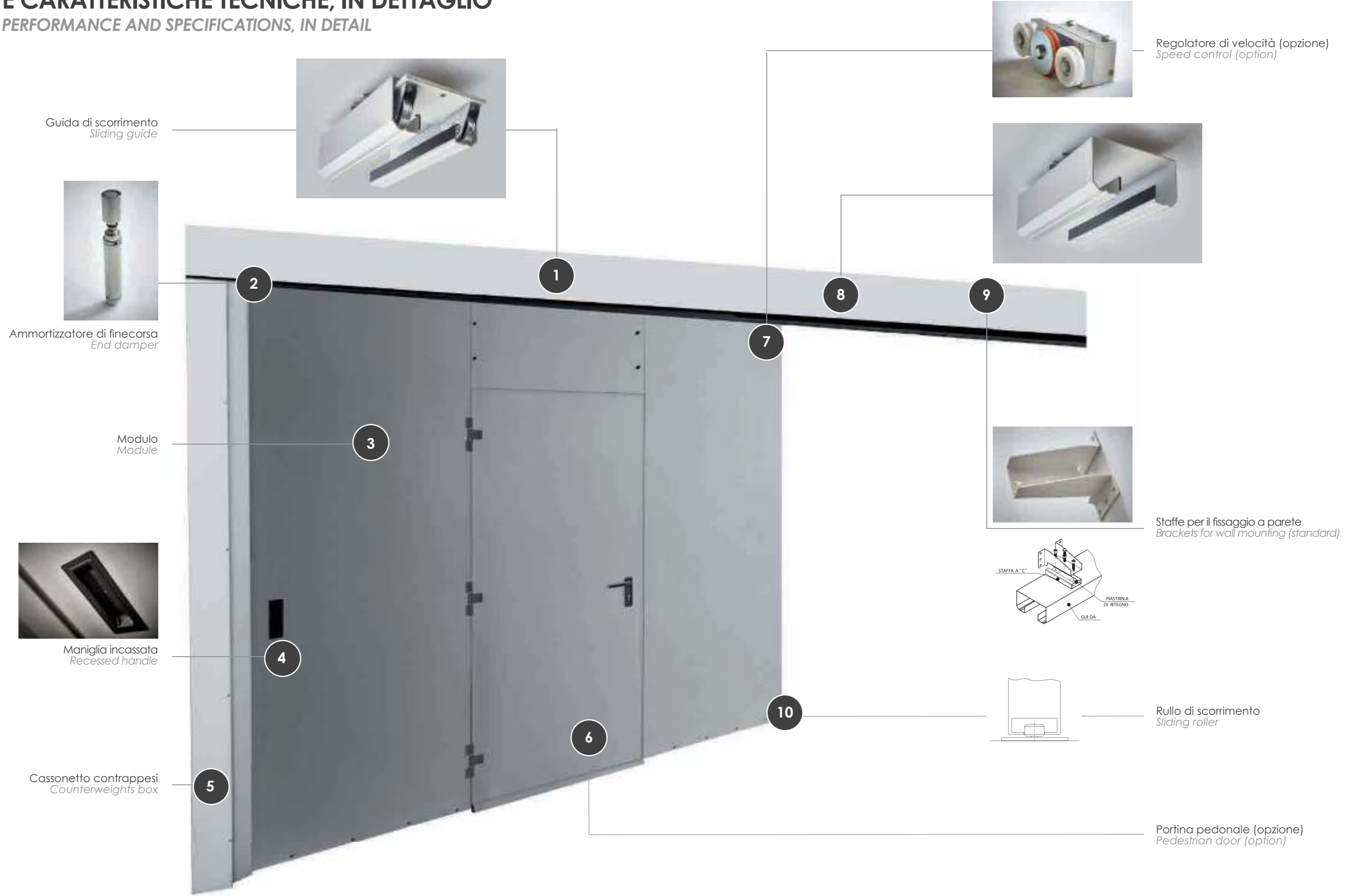

PERFORMANCE E CARATTERISTICHE TECNICHE, IN DETTAGLIO

PERFORMANCE AND SPECIFICATIONS, IN DETAIL

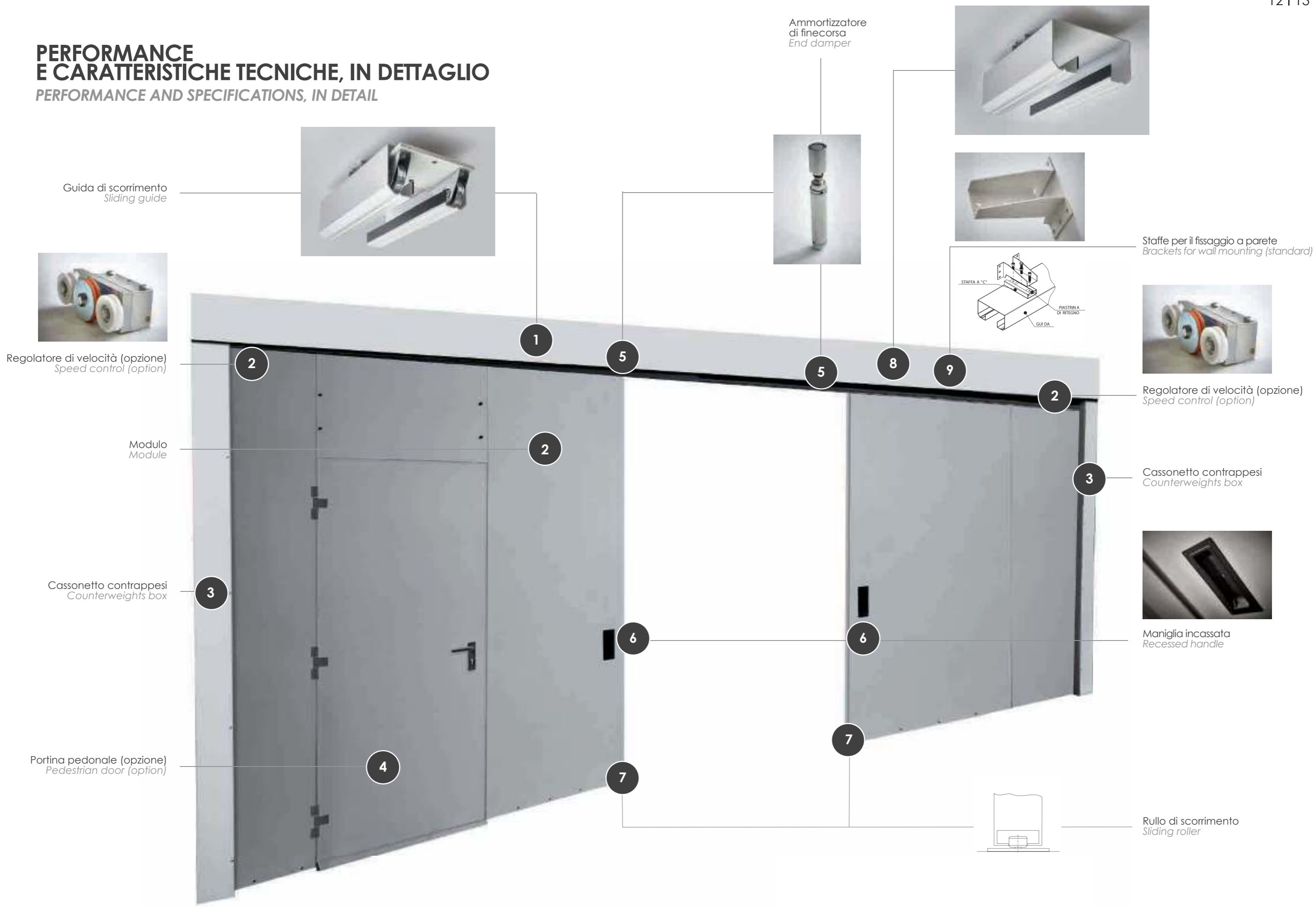

Guida di scorrimento
Sliding guide

Ammortizzatore di finecorsa
End damper



Staffe per il fissaggio a parete
Brackets for wall mounting (standard)



Regolatore di velocità (opzione)
Speed control (option)

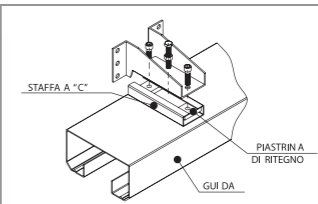

Regolatore di velocità (opzione)
Speed control (option)

Modulo
Module

Cassonetto contrappesi
Counterweights box

Cassonetto contrappesi
Counterweights box



Maniglia incassata
Recessed handle

Portina pedonale (opzione)
Pedestrian door (option)

Rullo di scorrimento
Sliding roller

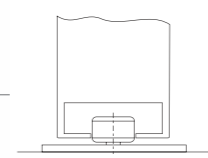

EXTRA PIÙ COMUNI

POPULAR EXTRAS

EXTRA PER ESIGENZE DI SICUREZZA

Porte normalmente aperte
Elettroblocchi antinfortunistici

EXTRA PER ESIGENZE D'IMPIEGO

Portine pedonali
Motorizzazione

EXTRA PER ESIGENZE ESTETICHE

Personalizzazione delle porte grazie
all'ampia gamma di finiture RAL

EXTRAS FOR SAFETY REQUIREMENTS

Normally open doors
Accident-prevention electroblocks

EXTRAS FOR USAGE REQUIREMENTS

Pedestrian doors
Motor system

AESTHETIC EXTRAS

Door customisation thanks to the
wide range of RAL finishings

FISSAGGIO A PARETE

WALL MOUNTING

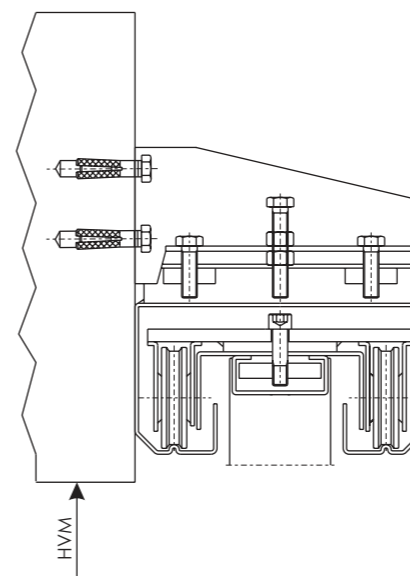

FISSAGGIO A SOFFITTO

CEILING MOUNTING

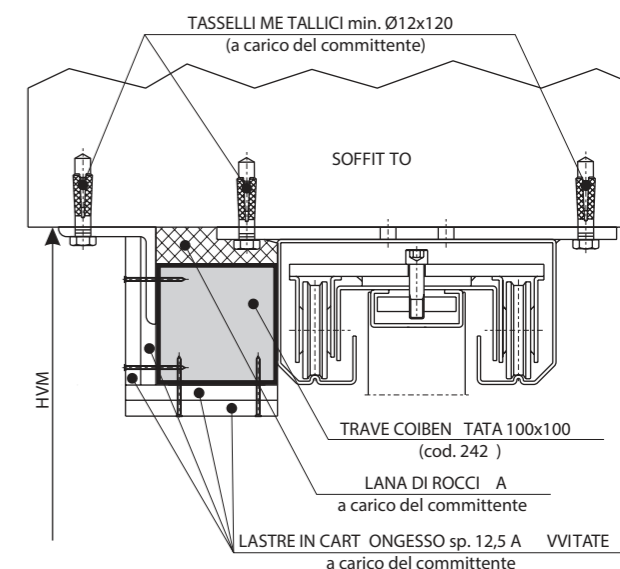

FISSAGGIO SU TRAVE TUBOLARE

FIXING ON TUBULAR BEAM

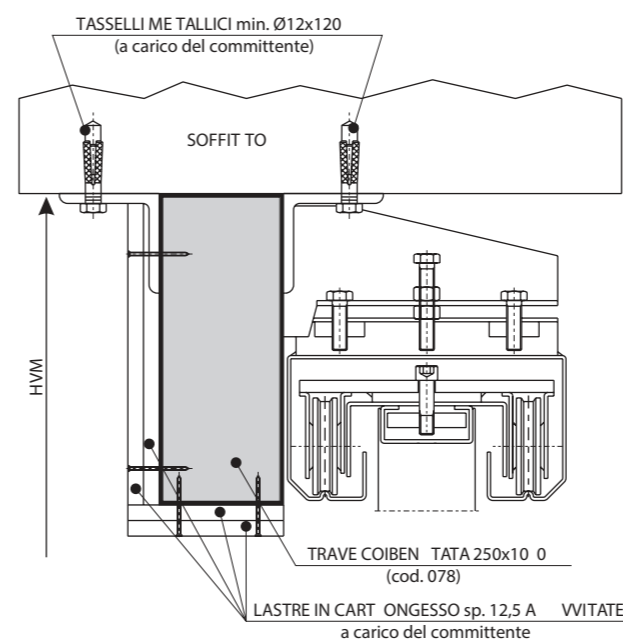

FISSAGGIO A SOFFITTO CON TIRANTI

(SOLO PER APPLICAZIONI OLTRELUCE)

CEILING MOUNTING WITH TIE RODS

(ONLY FOR FACE-FIXED APPLICATIONS)

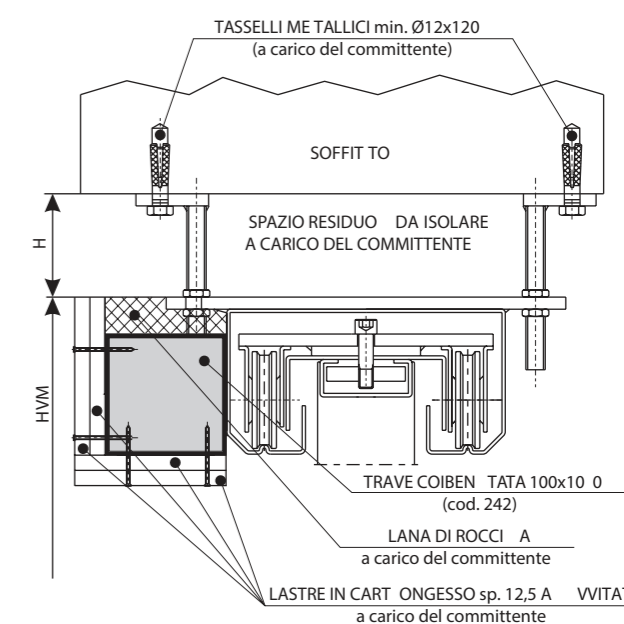





SCHEDE TECNICHE
TECHNICAL SHEETS

ROLLING EI₂ 120 1 BATTENTE (S01) | ROLLING EI₂ 120 SINGLE LEAF (S01)

EQUIPAGGIAMENTO DI SERIE STANDARD EQUIPMENT	
GUIDA DI SCORRIMENTO SLIDING GUIDE	
AMMORTIZZATORE (EXTRA OBBLIGATORIO) EXTRA DAMPER (MANDATORY)	
PIASTRINA TERMOFUSIBILE (soluzione NON consigliata) THERMAL FUSE PLATE (not recommended)	SI / YES
MARCATURA CE CE MARKING	
PESO WEIGHT	50 Kg/m ²

VARIANTI SUPPLEMENTARI ADDITIONAL VARIATIONS	
REGOLATORE DI VELOCITÀ SPEED ADJUSTER	SI / YES
PORTINA PEDONALE PEDESTRIAN DOOR	SI / YES
MOTORIZZAZIONE MOTORIZATION	SI / YES
ELETTROBLOCCO ANTINFORTUNISTICO (consigliato) ACCIDENT-PREVENTION ELECTROBLOCKS (recommended)	SI / YES
ELETTROMAGNETI (soluzione consigliata) ELECTROMAGNETS (recommended)	SI / YES
CONTRAPPESI DISASSATI OFFSET COUNTERWEIGHTS	NO

TIPOLOGIE DI FISSAGGIO TYPES OF FASTENING	
SU PARETE IN MURATURA ON MASONRY WALL	SI / YES
SU PARETE IN CARTONGESSO ON PLASTERBOARD WALL	NO
A PARETE ON THE WALL	 SI / YES
A SOFFITTO CEILING	 SI / YES
A SOFFITTO CON TIRANTI CEILING WITH TIE RODS	 SI / YES
SU TRAVE COIBENTATA ON INSULATED BEAM	 NO

FINITURE FINISHINGS	
LACCATA RAL PER ESTERNI EXTERIOR RAL LAQUERER	SI / YES

DIMENSIONI CERTIFICATE CERTIFIED DIMENSIONS (per la disponibilità nella propria nazione, chiedere al ns ufficio tecnico) (ask our technical assistance office for availability in your country)	
LARGHEZZA (LVM) WIDTH (LVM)	500 + 5000
ALTEZZA (HVM) HEIGHT (HVM)	1750 + 4725

Le quote sono espresse in millimetri
Dierre si riserva il cambiamento della presente senza preavviso
I disegni sono esemplificativi e fuori scala

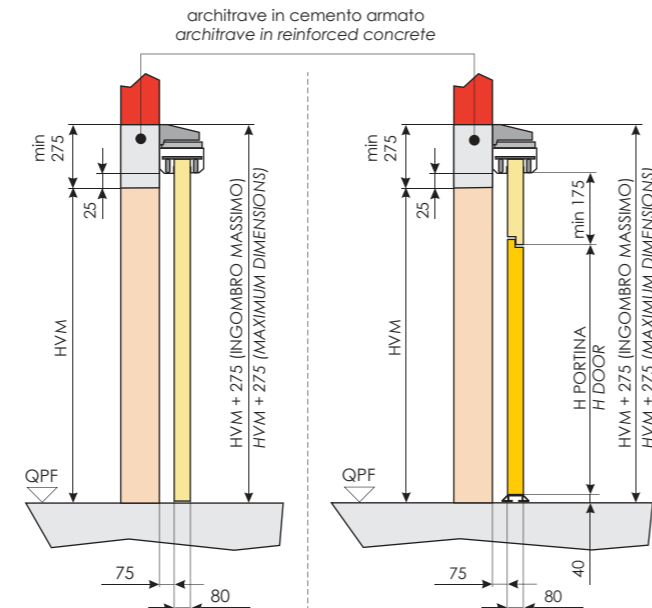
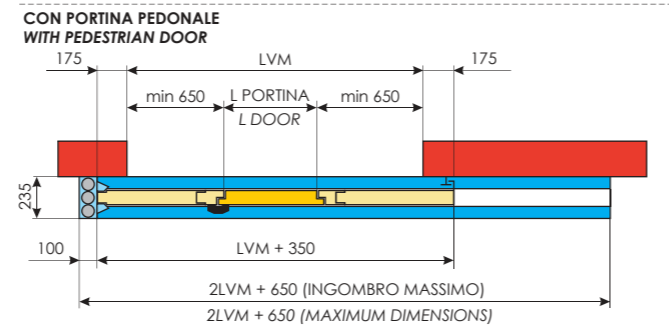
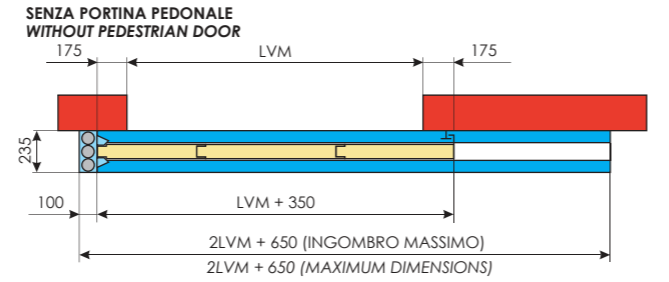

Dimensions are expressed in millimetres
Dierre holds the right to change this without notice
Drawing are examples and not in scale



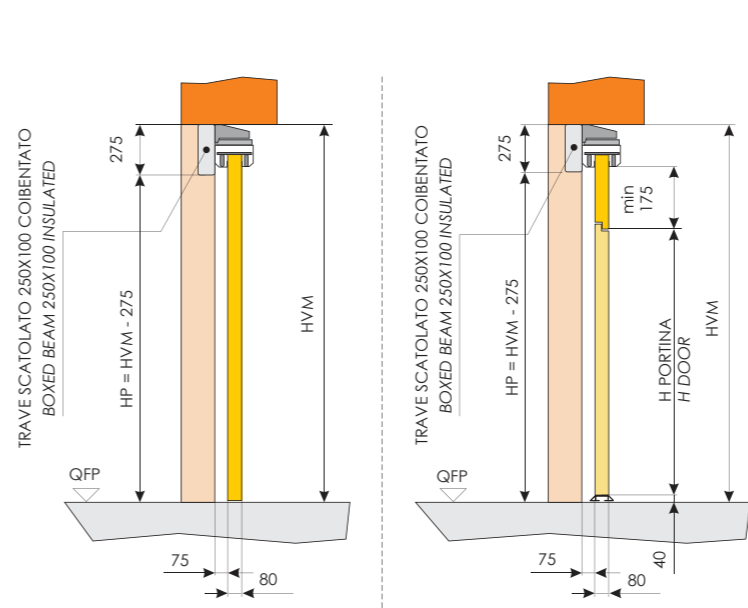
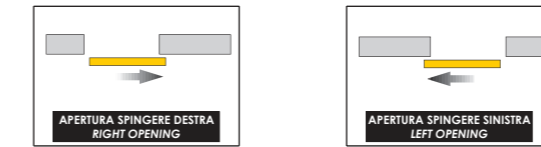
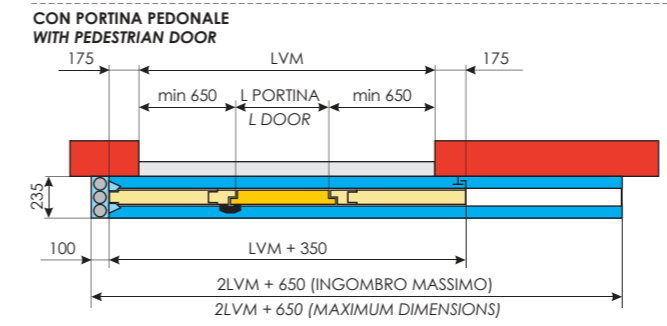
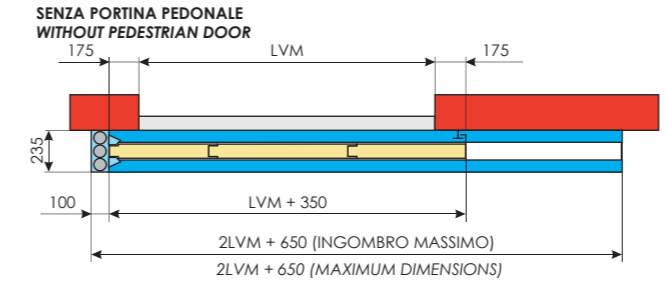



**SENZA PORTINA PEDONALE
WITHOUT PEDESTRIAN DOOR** **CON PORTINA PEDONALE
WITH PEDESTRIAN DOOR**



**SENZA PORTINA PEDONALE
WITHOUT PEDESTRIAN DOOR** **CON PORTINA PEDONALE
WITH PEDESTRIAN DOOR**

EQUIPAGGIAMENTO DI SERIE STANDARD EQUIPMENT	
GUIDA DI SCORRIMENTO SLIDING GUIDE	
AMMORTIZZATORE (EXTRA OBBLIGATORIO) EXTRA DAMPER (MANDATORY)	
PIASTRINA TERMOFUSIBILE (soluzione NON consigliata) THERMAL FUSE PLATE (not recommended)	SI / YES
MARCATURA CE CE MARKING	
PESO WEIGHT	50 Kg/m ²

VARIANTI SUPPLEMENTARI ADDITIONAL VARIATIONS	
REGOLATORE DI VELOCITÀ SPEED ADJUSTER	SI / YES
PORTINA PEDONALE PEDESTRIAN DOOR	SI / YES
MOTORIZZAZIONE MOTORIZATION	SI / YES
ELETTROBLOCCO ANTINFORTUNISTICO (consigliato) ACCIDENT-PREVENTION ELECTROBLOCKS (recommended)	SI / YES
ELETTROMAGNETI (soluzione consigliata) ELECTROMAGNETS (recommended)	SI / YES
CONTRAPPESI DISASSATI OFFSET COUNTERWEIGHTS	NO

TIPOLOGIE DI FISSAGGIO TYPES OF FASTENING	
SU PARETE IN MURATURA ON MASONRY WALL	SI / YES
SU PARETE IN CARTONGESSO ON PLASTERBOARD WALL	NO
A PARETE ON THE WALL	 NO
A SOFFITTO CEILING	 NO
A SOFFITTO CON TIRANTI CEILING WITH TIE RODS	 NO
SU TRAVE COIBENTATA ON INSULATED BEAM	 SI / YES

FINITURE FINISHINGS	
LACCATA RAL PER ESTERNI EXTERIOR RAL LAQUERER	SI / YES







DIMENSIONI CERTIFICATE CERTIFIED DIMENSIONS (per la disponibilità nella propria nazione, chiedere al ns ufficio tecnico) (ask our technical assistance office for availability in your country)	
LARGHEZZA (LVM) WIDTH (LVM)	500 + 5000
ALTEZZA (HVM) HEIGHT (HVM)	1750 + 4725

Le quote sono espresse in millimetri
Dierre si riserva il cambiamento della presente senza preavviso
I disegni sono esemplificativi e fuori scala

Dimensions are expressed in millimetres
Dierre holds the right to change this without notice
Drawing are examples and not in scale

ROLLING EI₂ 120 1 BATTENTE (SA1) | ROLLING EI₂ 120 SINGLE LEAF (SA1)

ROLLING E120 1 BATTENTE (SG1) | ROLLING E120 SINGLE LEAF (SG1)

EQUIPAGGIAMENTO DI SERIE STANDARD EQUIPMENT	
GUIDA DI SCORRIMENTO SLIDING GUIDE	
AMMORTIZZATORE (EXTRA OBBLIGATORIO) EXTRA DAMPER (MANDATORY)	
PIASTRINA TERMOFUSIBILE (soluzione NON consigliata) THERMAL FUSE PLATE (not recommended)	SI / YES
MARCATURA CE CE MARKING	
PESO WEIGHT	50 Kg/m ²
VARIANTI SUPPLEMENTARI ADDITIONAL VARIATIONS	
REGOLATORE DI VELOCITÀ SPEED ADJUSTER	SI / YES
PORTINA PEDONALE PEDESTRIAN DOOR	SI / YES
MOTORIZZAZIONE MOTORIZATION	SI / YES
ELETTROBLOCCO ANTINFORTUNISTICO (consigliato) ACCIDENT-PREVENTION ELECTROBLOCKS (recommended)	SI / YES
ELETTROMAGNETI (soluzione consigliata) ELECTROMAGNETS (recommended)	SI / YES
CONTRAPPESI DISASSATI OFFSET COUNTERWEIGHTS	NO
TIPOLOGIE DI FISSAGGIO TYPES OF FASTENING	
SU PARETE IN MURATURA ON MASONRY WALL	SI / YES
SU PARETE IN CARTONGESSO ON PLASTERBOARD WALL	NO
A PARETE ON THE WALL	 SI / YES
A SOFFITTO CEILING	 NO
A SOFFITTO CON TIRANTI CEILING WITH TIE RODS	 NO
SU TRAVE COIBENTATA ON INSULATED BEAM	 NO
FINITURE FINISHINGS	
LACCATA RAL PER ESTERNI EXTERIOR RAL LAQUERER	SI / YES
DIMENSIONI CERTIFICATE CERTIFIED DIMENSIONS (per la disponibilità nella propria nazione, chiedere al ns ufficio tecnico) (ask our technical assistance office for availability in your country)	
LARGHEZZA (LVM) WIDTH (LVM)	500 + 8100
ALTEZZA (HVM) HEIGHT (HVM)	1750 + 4725
MASSIMA SUPERFICIE (LVM X HVM) MAXIMUM SURFACE (LVM X HVM)	36 m ²

Le quote sono espresse in millimetri
Dierre si riserva il cambiamento della presente senza preavviso
I disegni sono esemplificativi e fuori scala

Dimensions are expressed in millimetres
Dierre holds the right to change this without notice
Drawing are examples and not in scale

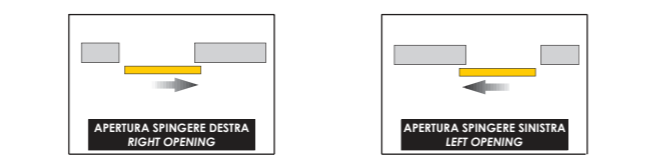
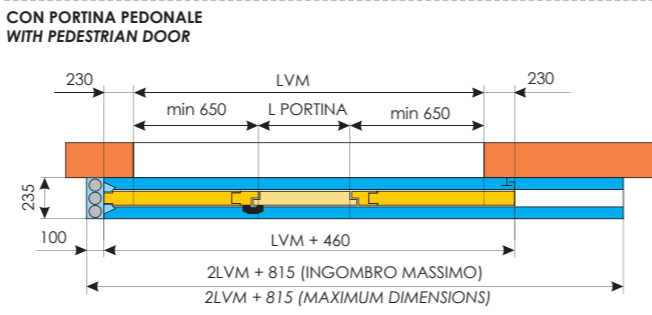
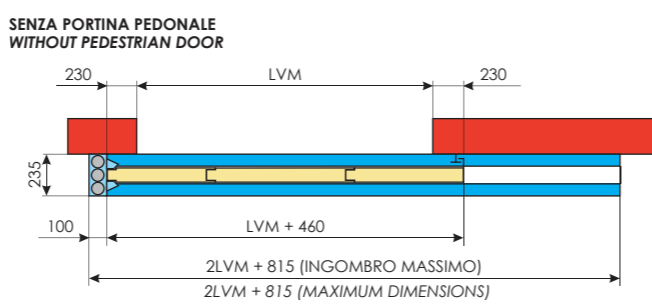



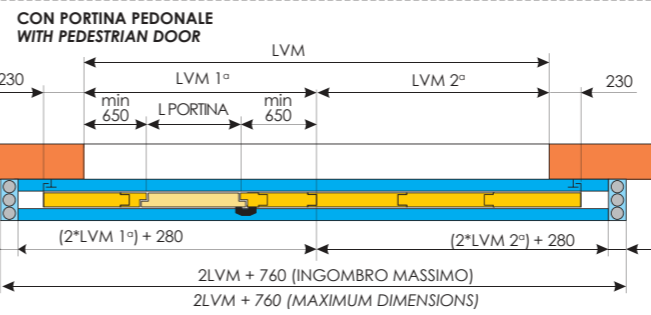
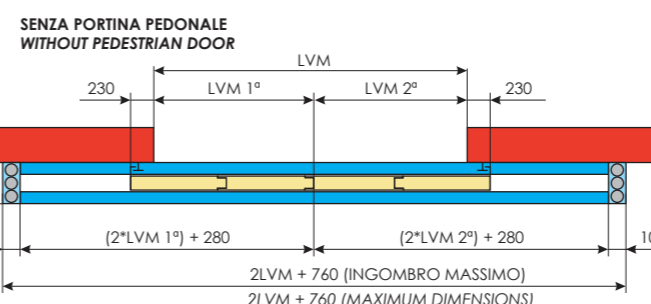
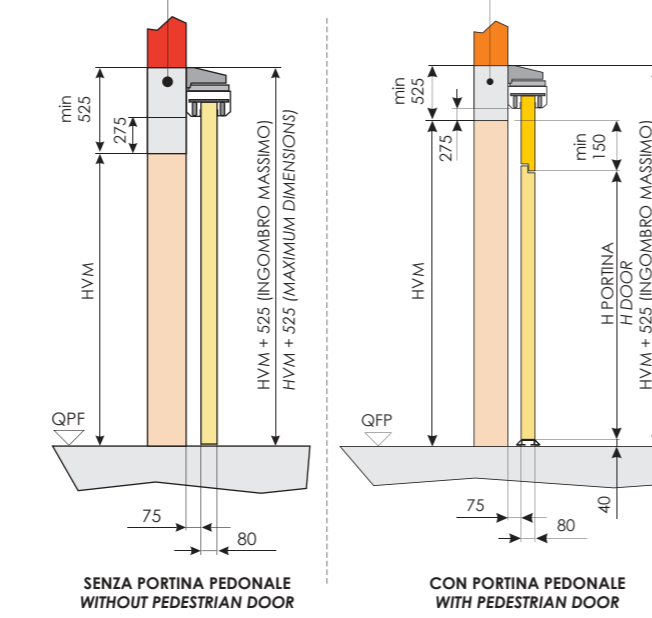

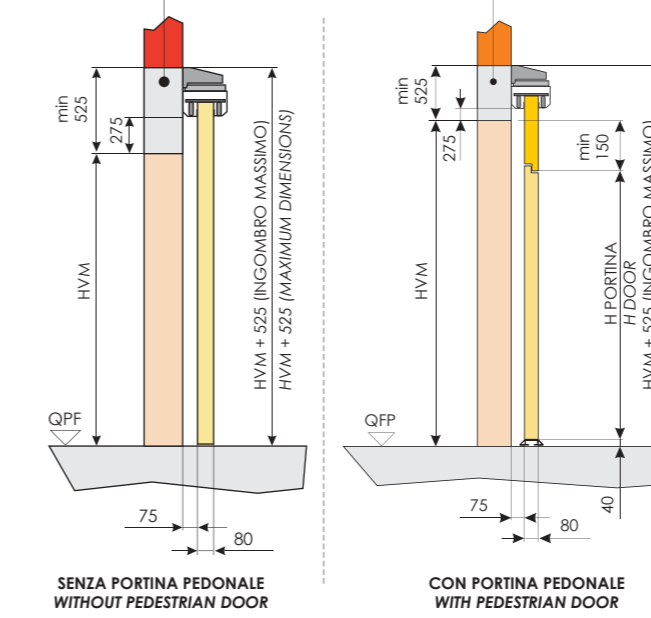

architrave in cemento armato per fissare le mensole di sostegno guida con tasselli metallici ad espansione Ø12x80, minimo



architrave in cemento armato per fissare le mensole di sostegno guida con tasselli metallici ad espansione Ø12x80, minimo









EQUIPAGGIAMENTO DI SERIE STANDARD EQUIPMENT	
GUIDA DI SCORRIMENTO SLIDING GUIDE	
AMMORTIZZATORE (EXTRA OBBLIGATORIO) EXTRA DAMPER (MANDATORY)	
PIASTRINA TERMOFUSIBILE (soluzione NON consigliata) THERMAL FUSE PLATE (not recommended)	SI / YES
MARCATURA CE CE MARKING	
PESO WEIGHT	50 Kg/m ²
VARIANTI SUPPLEMENTARI ADDITIONAL VARIATIONS	
REGOLATORE DI VELOCITÀ SPEED ADJUSTER	SI / YES
PORTINA PEDONALE PEDESTRIAN DOOR	SI / YES
MOTORIZZAZIONE MOTORIZATION	SI / YES
ELETTROBLOCCO ANTINFORTUNISTICO (consigliato) ACCIDENT-PREVENTION ELECTROBLOCKS (recommended)	SI / YES
ELETTROMAGNETI (soluzione consigliata) ELECTROMAGNETS (recommended)	SI / YES
CONTRAPPESI DISASSATI OFFSET COUNTERWEIGHTS	NO
TIPOLOGIE DI FISSAGGIO TYPES OF FASTENING	
SU PARETE IN MURATURA ON MASONRY WALL	SI / YES
SU PARETE IN CARTONGESSO ON PLASTERBOARD WALL	NO
A PARETE ON THE WALL	 SI / YES
A SOFFITTO CEILING	 NO
A SOFFITTO CON TIRANTI CEILING WITH TIE RODS	 NO
SU TRAVE COIBENTATA ON INSULATED BEAM	 NO
FINITURE FINISHINGS	
LACCATA RAL PER ESTERNI EXTERIOR RAL LAQUERER	SI / YES
DIMENSIONI CERTIFICATE CERTIFIED DIMENSIONS (per la disponibilità nella propria nazione, chiedere al ns ufficio tecnico) (ask our technical assistance office for availability in your country)	
LARGHEZZA (LVM) WIDTH (LVM)	500+500 + 6075+6075
ALTEZZA (HVM) HEIGHT (HVM)	1750 + 4725
MASSIMA SUPERFICIE (LVM X HVM) MAXIMUM SURFACE (LVM X HVM)	36 m ²

Le quote sono espresse in millimetri
Dierre si riserva il cambiamento della presente senza preavviso
I disegni sono esemplificativi e fuori scala

Dimensions are expressed in millimetres
Dierre holds the right to change this without notice
Drawing are examples and not in scale

ROLLING E120 2 BATTENTI (SG2) | ROLLING E120 DOUBLE LEAF (SG2)

ROLLING E120 1 BATTENTE (SB1) | ROLLING E120 SINGLE LEAF (SB1)

EQUIPAGGIAMENTO DI SERIE STANDARD EQUIPMENT	
GUIDA DI SCORRIMENTO SLIDING GUIDE	
AMMORTIZZATORE (EXTRA OBBLIGATORIO) EXTRA DAMPER (MANDATORY)	
PIASTRINA TERMOFUSIBILE (soluzione NON consigliata) THERMAL FUSE PLATE (not recommended)	SI / YES
MARCATURA CE CE MARKING	
PESO WEIGHT	50 Kg/m ²
VARIANTI SUPPLEMENTARI ADDITIONAL VARIATIONS	
REGOLATORE DI VELOCITÀ SPEED ADJUSTER	SI / YES
PORTINA PEDONALE PEDESTRIAN DOOR	SI / YES
MOTORIZZAZIONE MOTORIZATION	SI / YES
ELETTROBLOCCO ANTINFORTUNISTICO (consigliato) ACCIDENT-PREVENTION ELECTROBLOCKS (recommended)	SI / YES
ELETTROMAGNETI (soluzione consigliata) ELECTROMAGNETS (recommended)	SI / YES
CONTRAPPESI DISASSATI OFFSET COUNTERWEIGHTS	SI / YES
TIPOLOGIE DI FISSAGGIO TYPES OF FASTENING	
SU PARETE IN MURATURA ON MASONRY WALL	SI / YES
SU PARETE IN CARTONGESSO ON PLASTERBOARD WALL	NO
A PARETE ON THE WALL	 SI / YES
A SOFFITTO CEILING	 SI / YES
A SOFFITTO CON TIRANTI CEILING WITH TIE RODS	 SI / YES
SU TRAVE COIBENTATA ON INSULATED BEAM	 NO
FINITURE FINISHINGS	
LACCATA RAL PER ESTERNI EXTERIOR RAL LAQUERER	SI / YES
DIMENSIONI CERTIFICATE CERTIFIED DIMENSIONS (per la disponibilità nella propria nazione, chiedere al ns ufficio tecnico) (ask our technical assistance office for availability in your country)	
LARGHEZZA (LVM) WIDTH (LVM)	500 + 5000
ALTEZZA (HVM) HEIGHT (HVM)	1750 + 4725

Le quote sono espresse in millimetri
Dierre si riserva il cambiamento della presente senza preavviso
I disegni sono esemplificativi e fuori scala

Dimensions are expressed in millimetres
Dierre holds the right to change this without notice
Drawing are examples and not in scale

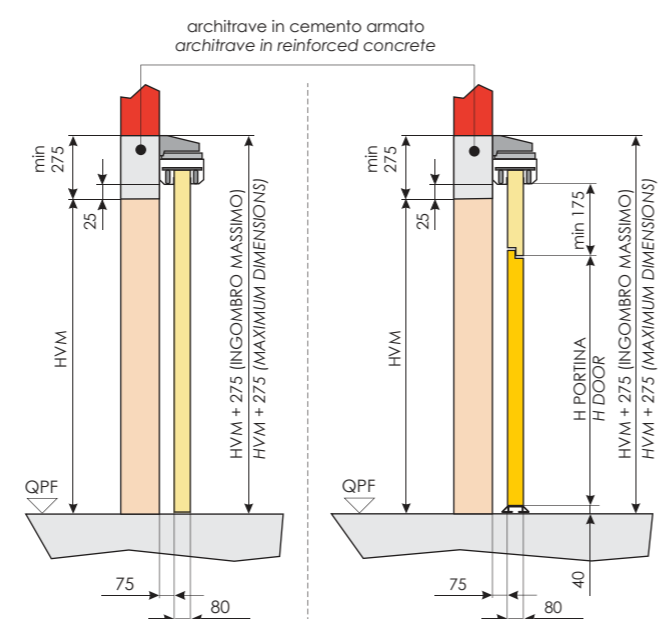
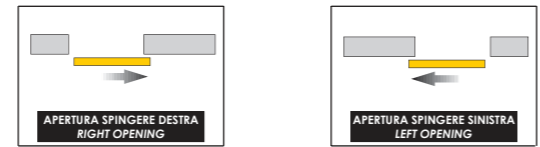
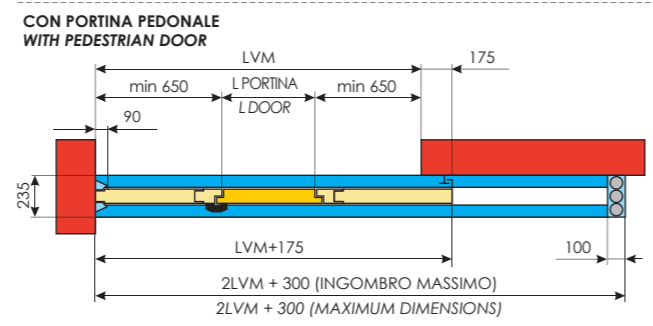
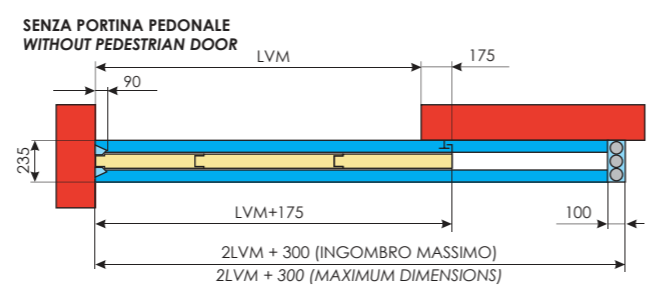





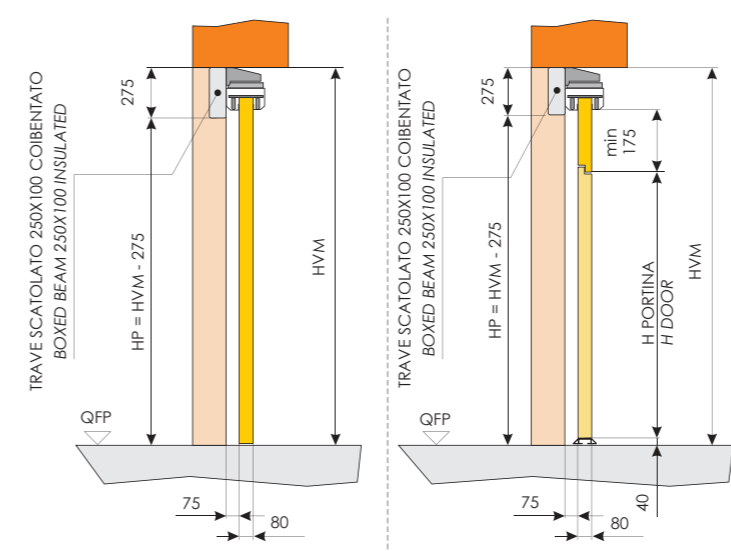
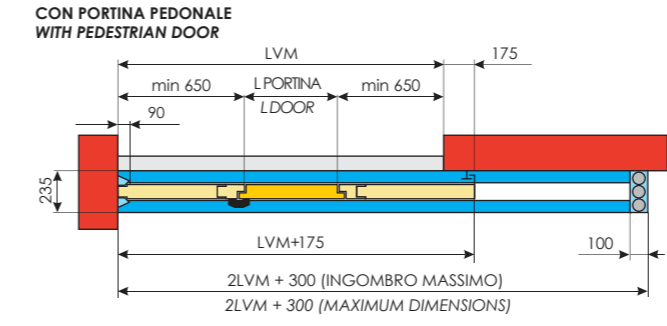
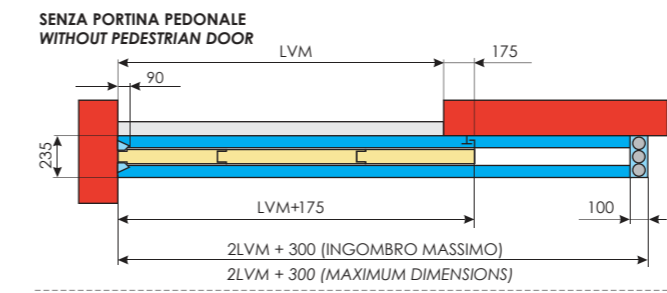

**SENZA PORTINA PEDONALE
WITHOUT PEDESTRIAN DOOR**

**CON PORTINA PEDONALE
WITH PEDESTRIAN DOOR**



**SENZA PORTINA PEDONALE
WITHOUT PEDESTRIAN DOOR**

**CON PORTINA PEDONALE
WITH PEDESTRIAN DOOR**

EQUIPAGGIAMENTO DI SERIE STANDARD EQUIPMENT	
GUIDA DI SCORRIMENTO SLIDING GUIDE	
AMMORTIZZATORE (EXTRA OBBLIGATORIO) EXTRA DAMPER (MANDATORY)	
PIASTRINA TERMOFUSIBILE (soluzione NON consigliata) THERMAL FUSE PLATE (not recommended)	SI / YES
MARCATURA CE CE MARKING	
PESO WEIGHT	50 Kg/m ²
VARIANTI SUPPLEMENTARI ADDITIONAL VARIATIONS	
REGOLATORE DI VELOCITÀ SPEED ADJUSTER	SI / YES
PORTINA PEDONALE PEDESTRIAN DOOR	SI / YES
MOTORIZZAZIONE MOTORIZATION	SI / YES
ELETTROBLOCCO ANTINFORTUNISTICO (consigliato) ACCIDENT-PREVENTION ELECTROBLOCKS (recommended)	SI / YES
ELETTROMAGNETI (soluzione consigliata) ELECTROMAGNETS (recommended)	SI / YES
CONTRAPPESI DISASSATI OFFSET COUNTERWEIGHTS	SI / YES
TIPOLOGIE DI FISSAGGIO TYPES OF FASTENING	
SU PARETE IN MURATURA ON MASONRY WALL	SI / YES
SU PARETE IN CARTONGESSO ON PLASTERBOARD WALL	NO
A PARETE ON THE WALL	 NO
A SOFFITTO CEILING	 NO
A SOFFITTO CON TIRANTI CEILING WITH TIE RODS	 NO
SU TRAVE COIBENTATA ON INSULATED BEAM	 SI / YES
FINITURE FINISHINGS	
LACCATA RAL PER ESTERNI EXTERIOR RAL LAQUERER	SI / YES
DIMENSIONI CERTIFICATE CERTIFIED DIMENSIONS (per la disponibilità nella propria nazione, chiedere al ns ufficio tecnico) (ask our technical assistance office for availability in your country)	
LARGHEZZA (LVM) WIDTH (LVM)	500 + 5000
ALTEZZA (HVM) HEIGHT (HVM)	1750 + 4725



Le quote sono espresse in millimetri
Dierre si riserva il cambiamento della presente senza preavviso
I disegni sono esemplificativi e fuori scala

Dimensions are expressed in millimetres
Dierre holds the right to change this without notice
Drawing are examples and not in scale

ROLLING E120 1 BATTENTE (SC1) | ROLLING E120 SINGLE LEAF (SC1)

EQUIPAGGIAMENTO DI SERIE STANDARD EQUIPMENT	
GUIDA DI SCORRIMENTO SLIDING GUIDE	
AMMORTIZZATORE (EXTRA OBBLIGATORIO) EXTRA DAMPER (MANDATORY)	
PIASTRINA TERMOFUSIBILE (soluzione NON consigliata) THERMAL FUSE PLATE (not recommended)	SI / YES
MARCATURA CE CE MARKING	
PESO WEIGHT	50 Kg/m ²

VARIANTI SUPPLEMENTARI ADDITIONAL VARIATIONS	
REGOLATORE DI VELOCITÀ SPEED ADJUSTER	SI / YES
PORTINA PEDONALE PEDESTRIAN DOOR	SI / YES
MOTORIZZAZIONE MOTORIZATION	SI / YES
ELETTROBLOCCO ANTINFORTUNISTICO (consigliato) ACCIDENT-PREVENTION ELECTROBLOCKS (recommended)	SI / YES
ELETTROMAGNETI (soluzione consigliata) ELECTROMAGNETS (recommended)	SI / YES
CONTRAPPESI DISASSATI OFFSET COUNTERWEIGHTS	SI / YES

TIPOLOGIE DI FISSAGGIO TYPES OF FASTENING	
SU PARETE IN MURATURA ON MASONRY WALL	SI / YES
SU PARETE IN CARTONGESSO ON PLASTERBOARD WALL	NO
A PARETE ON THE WALL	 SI / YES
A SOFFITTO CEILING	 SI / YES
A SOFFITTO CON TIRANTI CEILING WITH TIE RODS	 SI / YES
SU TRAVE COIBENTATA ON INSULATED BEAM	 NO



FINITURE FINISHINGS	
LACCATA RAL PER ESTERNI EXTERIOR RAL LAQUERER	SI / YES

DIMENSIONI CERTIFICATE CERTIFIED DIMENSIONS (per la disponibilità nella propria nazione, chiedere al ns ufficio tecnico) (ask our technical assistance office for availability in your country)	
LARGHEZZA (LVM) WIDTH (LVM)	500+500 + 3120+1880
ALTEZZA (HVM) HEIGHT (HVM)	1750 + 4725
MASSIMA SUPERFICIE (LVM X HVM) MAXIMUM SURFACE (LVM X HVM)	28 m ²

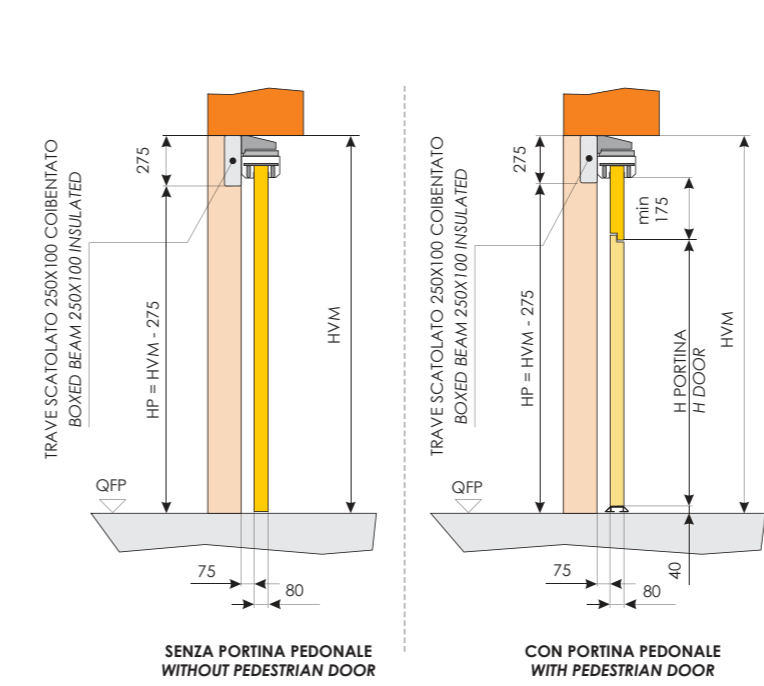
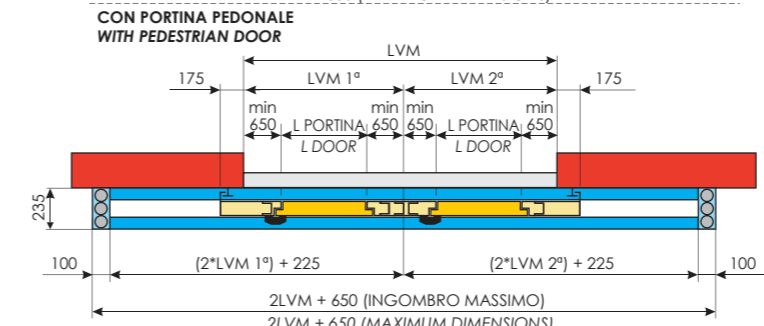
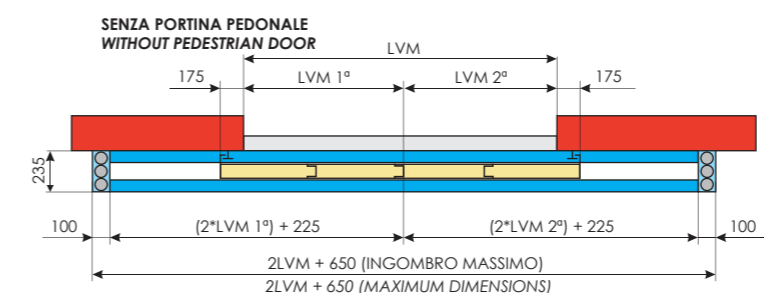
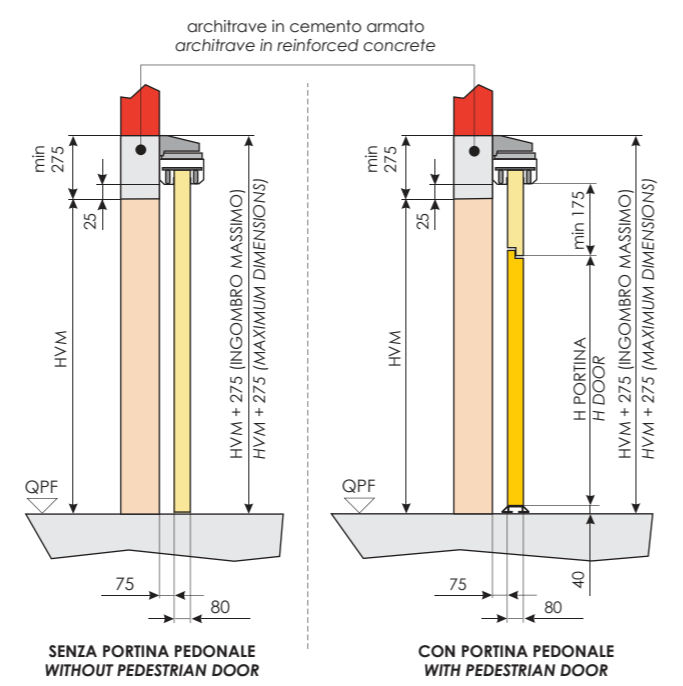
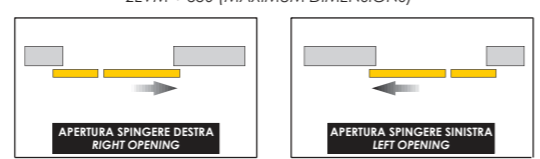
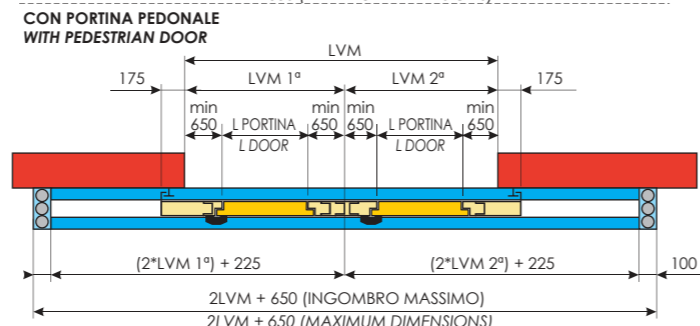
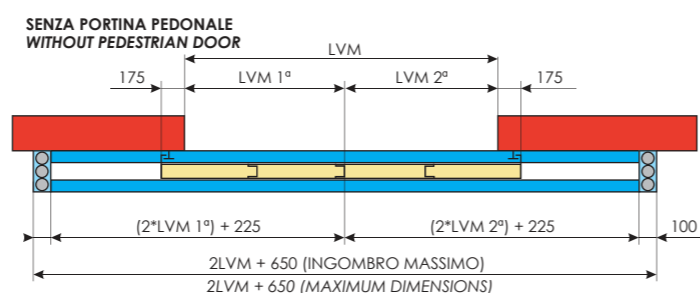

Le quote sono espresse in millimetri
Dierre si riserva il cambiamento della presente senza preavviso
I disegni sono esemplificativi e fuori scala

Dimensions are expressed in millimetres
Dierre holds the right to change this without notice
Drawing are examples and not in scale



EQUIPAGGIAMENTO DI SERIE STANDARD EQUIPMENT	
GUIDA DI SCORRIMENTO SLIDING GUIDE	
AMMORTIZZATORE (EXTRA OBBLIGATORIO) EXTRA DAMPER (MANDATORY)	
PIASTRINA TERMOFUSIBILE (soluzione NON consigliata) THERMAL FUSE PLATE (not recommended)	SI / YES
MARCATURA CE CE MARKING	
PESO WEIGHT	50 Kg/m ²

VARIANTI SUPPLEMENTARI ADDITIONAL VARIATIONS	
REGOLATORE DI VELOCITÀ SPEED ADJUSTER	SI / YES
PORTINA PEDONALE PEDESTRIAN DOOR	SI / YES
MOTORIZZAZIONE MOTORIZATION	SI / YES
ELETTROBLOCCO ANTINFORTUNISTICO (consigliato) ACCIDENT-PREVENTION ELECTROBLOCKS (recommended)	SI / YES
ELETTROMAGNETI (soluzione consigliata) ELECTROMAGNETS (recommended)	SI / YES
CONTRAPPESI DISASSATI OFFSET COUNTERWEIGHTS	SI / YES

TIPOLOGIE DI FISSAGGIO TYPES OF FASTENING	
SU PARETE IN MURATURA ON MASONRY WALL	SI / YES
SU PARETE IN CARTONGESSO ON PLASTERBOARD WALL	NO
A PARETE ON THE WALL	 NO
A SOFFITTO CEILING	 NO
A SOFFITTO CON TIRANTI CEILING WITH TIE RODS	 NO
SU TRAVE COIBENTATA ON INSULATED BEAM	 SI / YES

FINITURE FINISHINGS	
LACCATA RAL PER ESTERNI EXTERIOR RAL LAQUERER	SI / YES

DIMENSIONI CERTIFICATE CERTIFIED DIMENSIONS (per la disponibilità nella propria nazione, chiedere al ns ufficio tecnico) (ask our technical assistance office for availability in your country)	
LARGHEZZA (LVM) WIDTH (LVM)	500+500 + 3120+1880
ALTEZZA (HVM) HEIGHT (HVM)	1750 + 4725
MASSIMA SUPERFICIE (LVM X HVM) MAXIMUM SURFACE (LVM X HVM)	28 m ²

Le quote sono espresse in millimetri
Dierre si riserva il cambiamento della presente senza preavviso
I disegni sono esemplificativi e fuori scala

Dimensions are expressed in millimetres
Dierre holds the right to change this without notice
Drawing are examples and not in scale

CROSS

SCORREVOLE VERTICALE TAGLIAFUOCO AD USO PASSAVIVANDE

FIRE-RATED VERTICAL SLIDING SERVING HATCH

COMPONENTI FISSI: Guida verticale su 2 lati, fissata a muro tramite tasselli metallici con sagoma a tenuta fiamme e calore e carter di contenimento pesi, sporgenza guida dal muro 170 mm. Lato coda superiore, labirinto fisso per tenuta fiamme e calore fissato al muro tramite tasselli metallici, in accoppiamento con labirinto mobile avvitato sul lato coda dell'anta, assicura la tenuta delle fiamme e calore con anta chiusa. Tutti gli elementi fissi sono in lamiera zincata e verniciata con polvere epossipoliestere colore avorio chiaro simile al RAL 9010.

COMPONENTI SCORREVOLI: Anta scorrevole, sospesa alla guida tramite 2 cavi in acciaio collegati all'anta rinvii all'interno del carter delle guide verticali tramite 2 ruote di rinvio collocate all'estremità superiore della traversa di unione guide verticali. All'estremità del cavo rinvio nel carter della guida, sono sospesi i pesi di bilanciamento dell'anta, l'autochiusura si effettua dando prevalenza di sovrappeso all'anta, la quale si chiude per gravità. L'anta può essere composta da 1 o più moduli, i moduli si accoppiano con sistema maschio/femmina avvitati, il modulo lato festa è provvisto di maniglie incassate, il modulo lato coda è dotato di labirinto mobile di tenuta fiamme e calore, i moduli sono in lamiera di acciaio zincato e preverniciato avorio chiaro simile al RAL 9010 con pellicola di protezione da asportare a posa ultimata, coibentazione ad alta densità. Spessore anta 80 mm, aria tra anta e muro 50 mm. Apertura dal basso verso l'alto non necessita indicazione di mano d'apertura. Opzioni: avanzate coibentato (solo se in presenza di vincoli tecnico-architettonici), regolatore di velocità, ammortizzatori di fine corsa, motorizzazioni antincendio con possibilità funzionamento portone chiuso con blocco anta (antiapertura) tramite freno motore, verniciature RAL a scelta. Per misure in altezza superiore a 1 metro è consigliabile l'extra regolatore di velocità.

FIXED COMPONENTS: vertical guide on 2 sides, fixed to the wall by means of metal blocks flames and weights containment casing, guide overhang from the wall 170 mm. Upper end side, fixed labyrinth for flames fixed to the wall by means of metal blocks, coupled with mobile labyrinth screwed on the end side of the wing, ensures flames with the door closed. All fixed elements are in galvanized and epoxy polyester powder painted sheet metal, in light-ivory color similar to RAL 9010.

SLIDING COMPONENTS: Sliding leaf, suspended to the guide via 2 steel cables connected to the leaf and returned to the inside of the housing of the vertical guides via 2 idler wheels located at the upper end of the vertical guides union crosspiece. At the end of the returned cable in the housing of the guide are the suspended balance weights of the wing, the self-closure is carried out by giving the overweight prevalence to the wing, which closes by gravity. The wing can be composed by 1 or more modules, the modules are coupled with a male/female screwed system, the module on the top side is provided with recessed handles, the module on the end side is equipped flames mobile labyrinth seal, the modules are made of galvanized and prepainted sheet steel, light ivory similar to RAL 9010 with protective film to be removed once the laying operation is complete, high density insulation. Wing thickness 80 mm, space between the door and the wall 50 mm. Opening from the bottom upwards so does not require indication of the opening direction. Options: insulated sill (only if in the presence of technical-architectural constraints), speed control, end-of-stroke dampers, fire-rated motors with possibility of operation of closed door with wing block (opening-prevention) via motor brake, RAL painting at choice. For measurements of height over 1 meter the extra speed regulator is recommended.

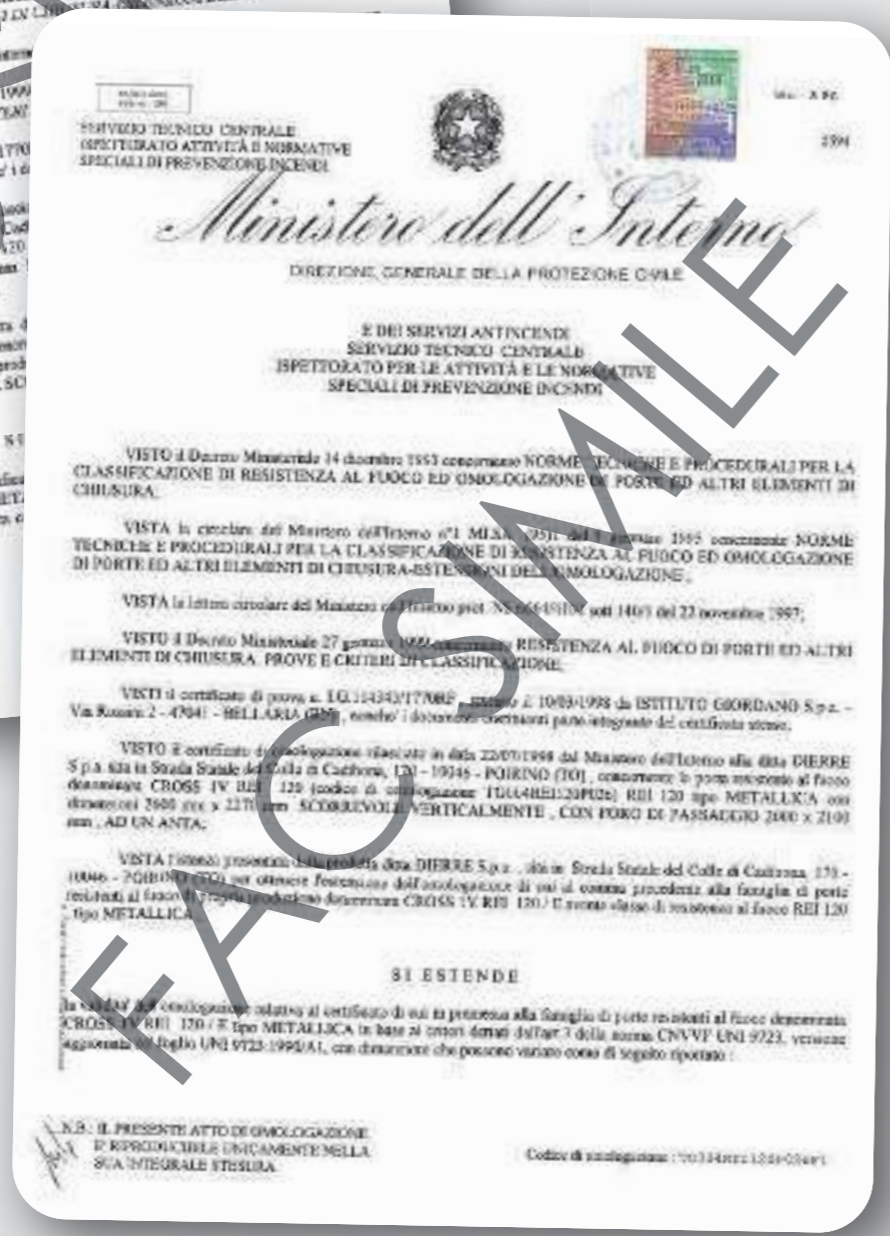

CERTIFICAZIONI E CONFORMITÀ DI PRODOTTO

Cross è classificato omologato per la resistenza al fuoco secondo la norma Italiana UNI 9723. **Il Cross è classificato e omologato REI 120.** Il termine "REI" sigla la capacità di un prodotto di conservare, in caso di incendio, alcune caratteristiche per un tempo stabilito, 120 minuti nel caso del Cross. Ogni lettera si riferisce a una diversa caratteristica: **R** indica la stabilità intesa come attitudine a conservare la resistenza meccanica sotto l'azione del fuoco; **E** indica la capacità di non lasciare passare la fiamma sul lato non esposto al fuoco; **I** indica l'isolamento termico inteso come attitudine a ridurre la trasmissione di calore.

CERTIFICATIONS AND PRODUCT CONFORMITY

Cross is certified and type-approved for its fire resistance following the Italian EN 1634 standard. **Cross is REI 120 certified and type-approved.** The term "REI" indicates the capacity of a product to retain certain characteristics in the event of fire for a given time: 120 minutes for Cross. Each letter indicates a different characteristic. **R** means stability as the ability to maintain mechanical resistance under the action of fire; **E** means the ability of not letting the flame go through on the side not exposed to fire; **I** indicates thermal insulation being the ability of the door to reduce heat transmission.

PERFORMANCE E CARATTERISTICHE TECNICHE, IN DETTAGLIO

PERFORMANCE AND SPECIFICATIONS, IN DETAIL



Regolatore di velocità (opzione)
Speed control (option)



Cassonetto contrappesi
Counterweights box



Maniglia incassata
Recessed handle



1

2

3

EXTRA PIÙ COMUNI

POPULAR EXTRAS

EXTRA PER ESIGENZE ESTETICHE

Personalizzazione delle porte grazie
all'ampia gamma di finiture RAL

AESTHETIC EXTRAS

Door customisation thanks to the
wide range of RAL finishings

SCHEDE TECNICHE
TECHNICAL SHEETS

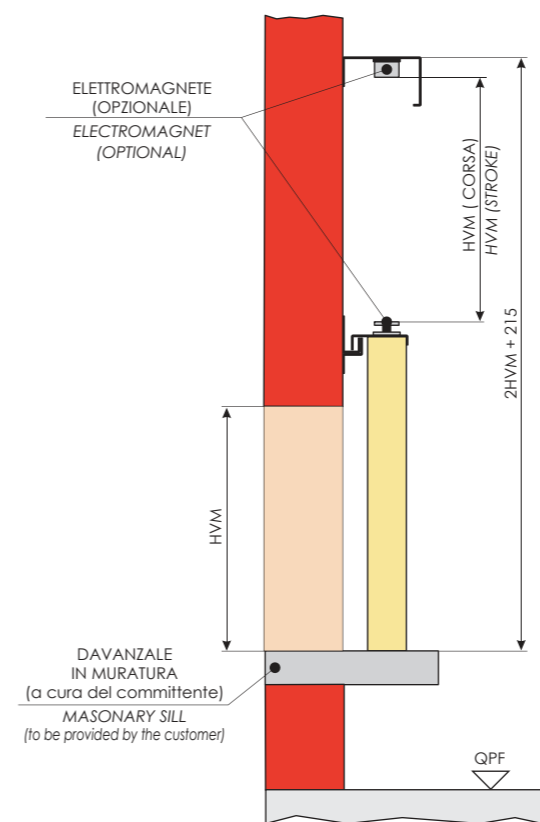
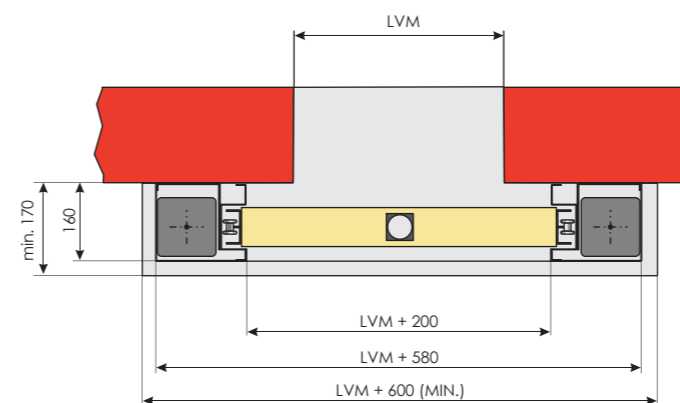

**EQUIPAGGIAMENTO DI SERIE
STANDARD EQUIPMENT**

PIASTRINA TERMOFUSIBILE (soluzione NON consigliata)
THERMAL FUSE PLATE (not recommended) SI / YES

PESO
WEIGHT 50 Kg/m²

**VARIANTI SUPPLEMENTARI
ADDITIONAL VARIATIONS**

REGOLATORE DI VELOCITÀ
SPEED ADJUSTER SI / YES

ELETTROMAGNETI (soluzione consigliata)
ELECTROMAGNETS (recommended) SI / YES

**TIPOLOGIE DI FISSAGGIO
TYPES OF FASTENING**

SU PARETE IN MURATURA
ON MASONRY WALL SI / YES

SU PARETE IN CARTONGESSO
ON PLASTERBOARD WALL NO

**FINITURE
FINISHINGS**

LACCATA RAL PER ESTERNI
EXTERIOR RAL LAQUERER SI / YES

**DIMENSIONI CERTIFICATE (per la disponibilità nella propria nazione, chiedere al ns ufficio tecnico)
CERTIFIED DIMENSIONS (ask our technical assistance office for availability in your country)**

LARGHEZZA (LVM)
WIDTH (LVM) 500 + 3900

ALTEZZA (HVM)
HEIGHT (HVM) 500 + 4000

MASSIMA SUPERFICIE (LVM X HVM)
MAXIMUM SURFACE (LVM X HVM) 10,5 m²

PRODOTTO NON CERTIFICATO

Le quote sono espresse in millimetri
Dierre si riserva il cambiamento della presente senza preavviso
I disegni sono esemplificativi e fuori scala

Dimensions are expressed in millimetres
Dierre holds the right to change this without notice
Drawing are examples and not in scale

TAVOLA SINOTTICA
SYNOPTIC TABLE

		CROSS REI 120 (cod. S05) pag. 32	ROLLING 1 B E ₂ 120 (cod. S01) pag. 18	ROLLING 1 B E ₂ 120 (cod. SA1) pag. 19	ROLLING 1 B E ₂ 120 (cod. SG1) pag. 20	ROLLING 1 B E ₂ 120 (cod. SB1) pag. 22	ROLLING 1 B E ₂ 120 (cod. SC1) pag. 23	ROLLING 2B E ₂ 120 (cod. SG2) pag. 21	ROLLING 2B E ₂ 120 (cod. S02) pag. 24	ROLLING 2B E ₂ 120 (cod. SA2) pag. 25
PORTONE STANDARD STANDARD DOOR										
RESISTENZA AL FUOCO RESISTANCE TO FIRE		REI 120	E ₂ 120	E ₂ 120	E ₂ 120	E ₂ 120	E ₂ 120	E ₂ 120	E ₂ 120	E ₂ 120
CERTIFICATO CERTIFICATE		●	●	●	●	●	●	●	●	●
MARCATURE CE CE MARKING		○	●	●	●	●	●	●	●	●
GUIDA GUIDE		○	●	●	●	●	●	●	●	●
AMMORTIZZATORE DAMPER		●	●	●	●	●	●	●	●	●
PIASTRINA TERMOFUSIBILE THERMAL FUSE PLATE		●	●	●	●	●	●	●	●	●
MOVIMENTO MOVEMENT										
SCORREVOLE VERTICALE VERTICAL SLIDING		●	○	○	○	○	○	○	○	○
SCORREVOLE ORIZZONTALE HORIZONTAL SLIDING		○	●	●	●	●	●	●	●	●
EXTRA SUPPLEMENTARI ADDITIONAL EXTRAS										
REGOLATORE DI VELOCITÀ SPEED CONTROL		●	●	●	●	●	●	●	●	●
PORTINA PEDONALE PEDESTRIAN DOOR		○	●	●	●	●	●	●	●	●
MOTORIZZAZIONE MOTOR SYSTEM		○	●	●	●	●	●	●	●	●
CONTRAPPESI DISASSATI OFFSET COUNTERWEIGHTS		○	○	○	○	●	●	●	●	●
ELETTROMAGNETI (soluzione consigliata) ELECTROMAGNETS (recommended)		●	●	●	●	●	●	●	●	●
FINITURE FINISHINGS										
LACCATA RAL PER ESTERNI EXTERIOR RAL LAQUERER		●	●	●	●	●	●	●	●	●
FISSAGGIO FASTENING										
SU PARETE IN MURATURA ON MASONRY WALL		●	●	●	●	●	●	●	●	●
SU PARETE IN CARTONGESSO ON PLASTERBOARD WALL		○	○	○	○	○	○	○	○	○
A PARETE ON THE WALL		●	●	○	●	●	○	●	●	●
A SOFFITTO CEILING		○	●	○	○	●	○	●	●	●
A SOFFITTO CON TIRANTI CEILING WITH TIE RODS		○	●	○	○	●	○	●	●	●
SU TRAVE TUBOLARE ON INSULATED BEAM		○	○	●	○	○	●	○	○	○
FISSAGGIO FASTENING										
LARGHEZZA (LVM) WIDTH (LVM)		500 + 3900	500 + 10000	500 + 10000	500 + 6075	500 + 10000	500 + 10000	500+500 3120+1880	500+500 3120+1880	500+500 3120+1880
ALTEZZA (HVM) HEIGHT (HVM)		500 + 4000	1750 + 5000	1750 + 5000	500 + 5000	1750 + 5000	1750 + 5000	1750 + 4725	1750 + 4725	1750 + 4725
MASSIMA SUPERFICIE (LVM X HVM) MAXIMUM SURFACE (LVM X HVM)		10,5 m ²	28 m ²	28 m ²	26 m ²	28 m ²	28 m ²	28 m ²	28 m ²	28 m ²



REFERENZE

Covi Srl - Busnago (MB)

1-2-3

Permedica Spa - Merate (LC)

4

4

THE ITALIAN STYLE DOOR

